

MACHINE VISION CAMERA

CamPerform

CP70-16-M/C-148



- METROLOGY AND HIGH SPEED MACHINE VISION
- MOTION ANALYSIS
- BROADCAST

- 148 fps with 4 672 x 3 416 pixels
- Global shutter with low noise pixel
- New DIN 1.0/2.3 connectors with thread lock
- CoaXPress interface with 25 Gbit/s
- Power and trigger via CoaXPress
- Microsecond and frame counter

FEATURES

The CP70-16-M/C-148 is a very high resolution camera with low noise pixels. Frame rate increase is possible by vertical but also horizontal resolution reduction. This makes the camera a flexible tool for many applications and measurement tasks.

- 4 672 x 3 416 pixel resolution
- low noise pixel
- frame rate increases with vertical and horizontal window size reduction

Firmware features

- Analogue gain adjustment
- Analogue offset adjustment
- Hot pixel correction (customer activatable)
- Framenumber and Microsecond counter on image

SPECIFICATIONS

Sensor type	LUX160, Global Shutter
Resolution	4 672 pixel x 3 416 pixel
Frame rate (full resolution)	20 .. 148 fps
Exposure time	4 µs .. 1 / frame rate
Active area / Diagonal	18.221 mm x 13.322 mm / 22.572 mm
Pixel size	3.9 µm x 3.9 µm
A/D conversion	8 Bit
Sensitivity (sensor)	5 V/lux·s @ 550 nm
Synchronization	internal, external, CoaXPress
Synchronization signals	Synch IN and Synch OUT, TTL level, electrically isolated
Interface	CoaXPress 1.1 (4 ch., CXP-6) DIN 1.0/2.3 connectors
Power	<10 W, PoCXP, ext.
Operating ambient temperature	0 .. +40°C / 32 .. 104°F
Weight	400 g without mount
Dimensions	85 mm x 85 mm x 49 mm (3D model data available)

EMVA1288 camera measurements (typ. Preliminary)

Dynamic range	55 dB
Saturation capacity	7 800 e ⁻
Temporal dark noise	10 e ⁻
System gain	34 e ⁻ /DN
Signal-to-Noise Ratio	39 dB
DSNU	135 e ⁻
PRNU	2 %
Non-linearity error LE _{min} , LE _{max}	1 %

PERFORMANCE (EXAMPLES)

Resolution (HxV)	Frame rate	Resolution (HxV)	Frame rate
4 672 x 3 416	148 fps	4 672 x 512	988 fps
4 080 x 3 072	187 fps	4 672 x 256	1 968 fps
4 080 x 2 048	281 fps	4 672 x 128	3 907 fps
2 048 x 1 024	1 012 fps	4 672 x 32	14 939 fps
1 024 x 512	2 021 fps	2 048 x 32	30 557 fps

MODELS

Article number	Description
CP70-16-M-148	monochrome Camera
CP70-16-C-148	color Camera
Scope of delivery	Camera, brief introduction

ACCESSORIES

Lens mounts: C-mount, F-mount, G-mount, M42-mount

Power supply, pig tail cable, programming cable

TECHNICAL DRAWING

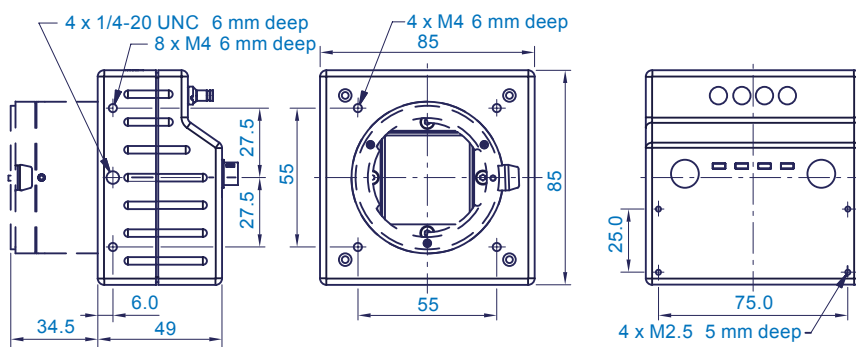

CONTACT INFORMATION

Optronis GmbH
Ludwigstraße 2
77694 Kehl
Germany

Phone: +49 7851 91 26 - 0
Fax: +49 7851 91 26 - 10
info@optronis.com
www.optronis.com